

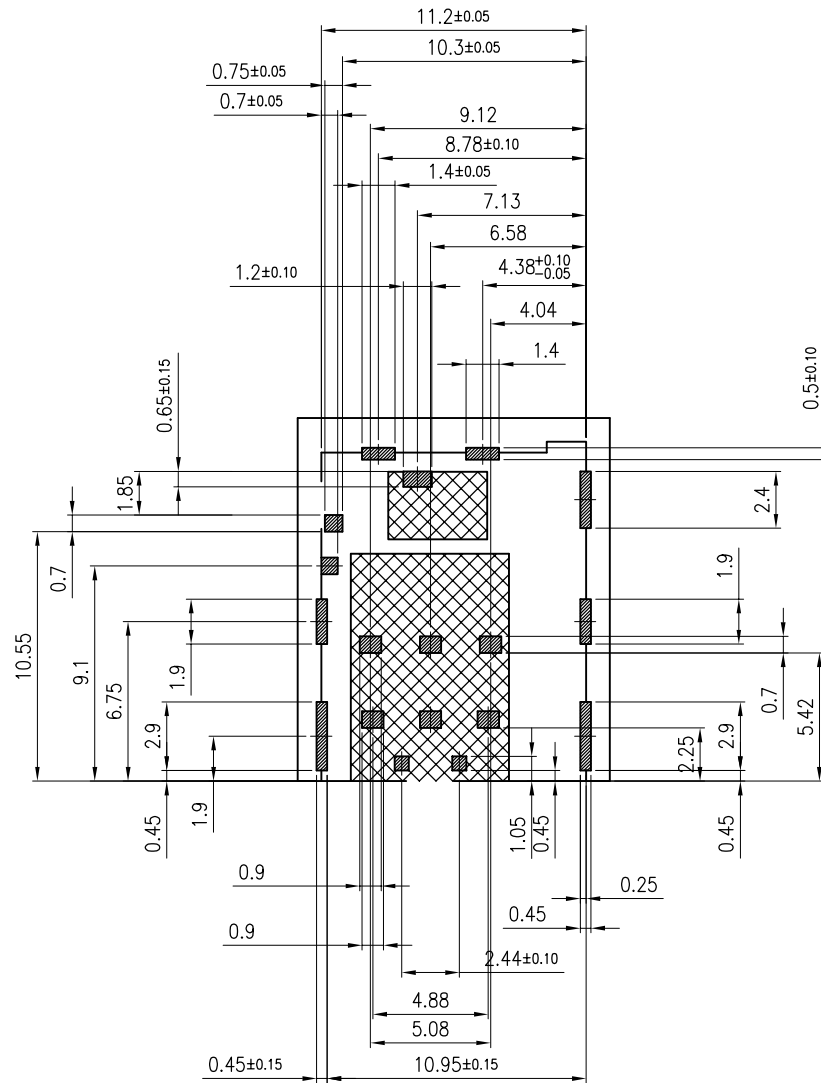

RoHS

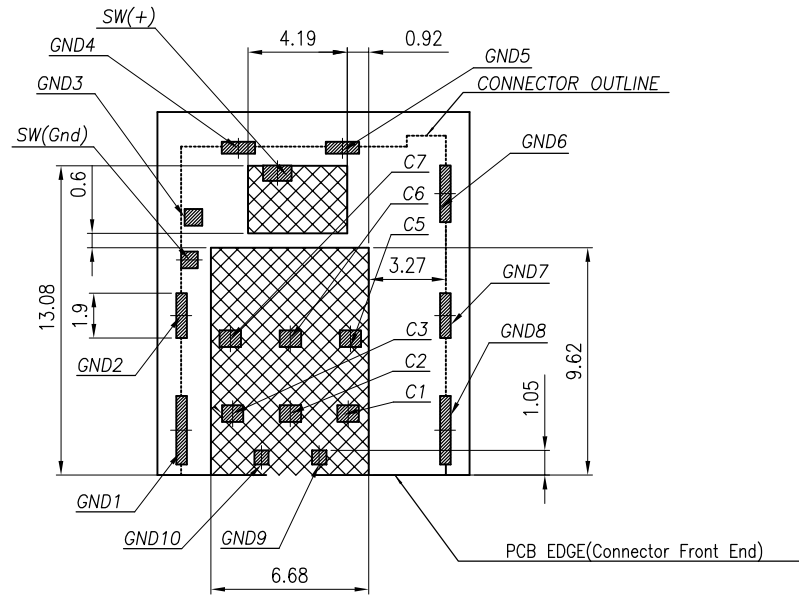

RECOMMENDED PCB LAYOUT TOP VIEW (TOLERANCE:±0.05)  
RECOMMENDED METAL MASK T=0.12MM



- NO PATTERN AND VIA HOLE IN HTIS AREA
- SMT SOLDER AREA

MILLIMETERS	INCH	UNITS	慈溪市卡连电子有限公司 CIXI CARDCONN ELECTRONIC CO., LTD									
		MM										
X° ± 2°	X° ± 2°	MAT'L	PART NUMBER: SCC102322824		TITLE: NANO SIM 6PIN H1.25MM P/P客户图							
.X ± 0.25	.XX ± 0.012	SEE NOTES										
.XX ± 0.20	.XXX ± 0.008	FINISH	APPD:		DWG NO.: SCC-102322824-00							
.XXX ± 0.10	.XXXX ± 0.004	SEE NOTES										
THESE DRAWINGS AND SPECIFICATIONS ARE THE PROPERTY OF CIXI CARDCONN ELECTRONIC CO.,LTD. COPIED OR USED IN ANY MANNER WITHOUT THE PRIOR WRITTEN CONSENT OF CIXI CARDCONN ELECTRONIC CO.,LTD			QTY	CHKD:	<table border="1" style="font-size: small;"> <tr> <th>SCALE</th> <th>SHEET</th> <th>REV.</th> </tr> <tr> <td>1:1</td> <td>2/3</td> <td>X2</td> </tr> </table>		SCALE	SHEET	REV.	1:1	2/3	X2
			SCALE	SHEET			REV.					
1:1	2/3	X2										
			SEE NOTES	DR:								

RoHS

USER DIRECTION OF UNREELING →

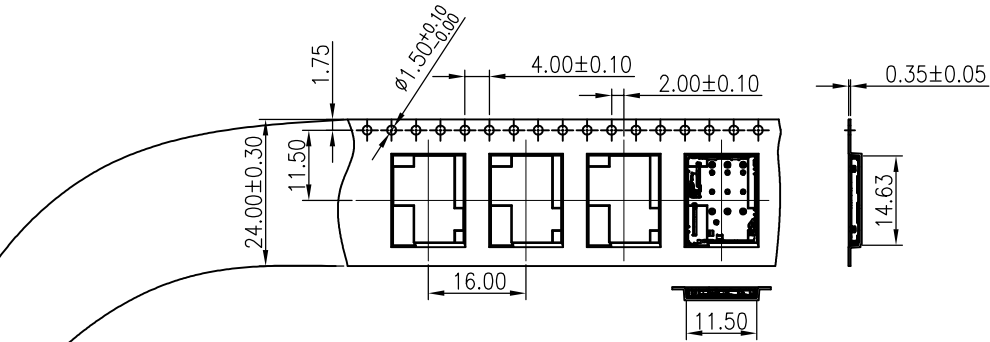

NOTES

1. NUMBER OF CONNECTORS: 2000PCS/REEL
2. LEAD TAPE LENGTH

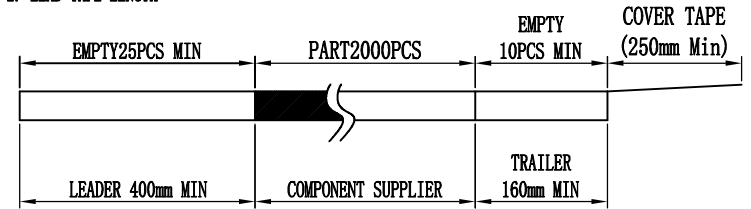

3. QUANTITY: 20000PCS/CARTON

COVER TAPE PEELING ANGLE: 165°~180°  
PEELING FORCE: 20~130g

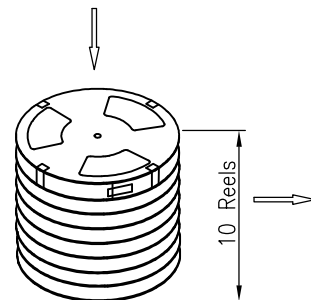
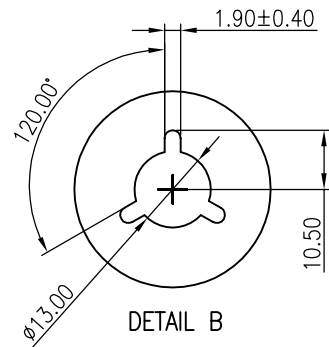
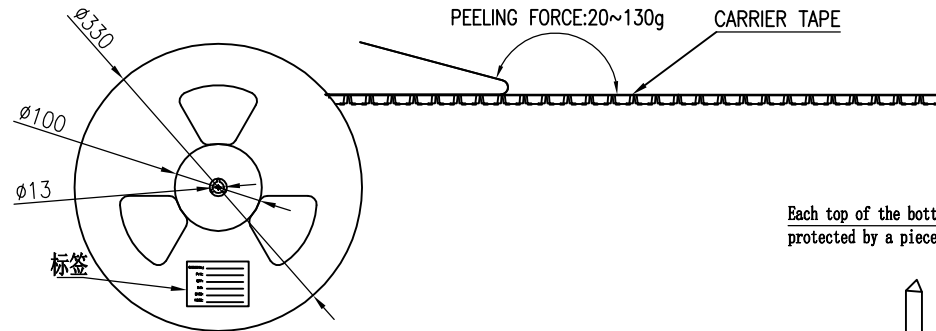

Each top of the bottom of the carton is protected by a piece of pearl cotton

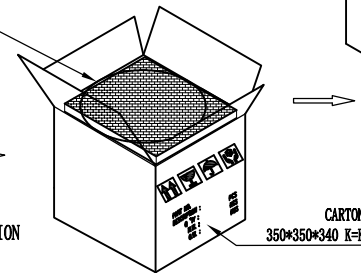
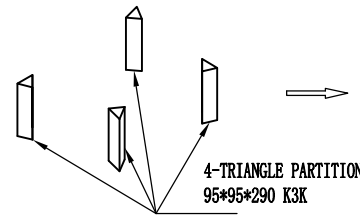

10 rolls per carton

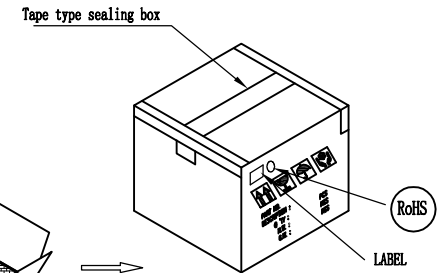

MILLIMETERS	INCH	UNITS	MM				
X° ± 2'	X° ± 2'	MAT'L	 <b>慈溪市卡连电子有限公司</b> CIXI CARDCONN ELECTRONIC CO., LTD				
.X ± 0.30	.XX ± 0.012	SEE NOTES					
.XX ± 0.20	.XXX ± 0.008	FINISH					
.XXX ± 0.10	.XXXX ± 0.004	SEE NOTES					
THESE DRAWINGS AND SPECIFICATIONS ARE THE PROPERTY OF CIXI CARDCONN ELECTRONIC CO.,LTD. COPIED OR USED IN ANY MANNER WITHOUT THE PRIOR WRITTEN CONSENT OF CIXI CARDCONN ELECTRONIC CO.,LTD							
QTY	SEE NOTES	DR:	PART NUMBER: SCC102322824	TITLE: NANO SIM 6PIN H1.25MM P/P客户图	DWG NO.: SCC-102322824-00		
			APPD:	CHKD:	SCALE	SHEET	REV.
			DR:		1:1	3/3	X2