

TW164



When precision matters.®

TW164 1-to-4 Port Smart Power GNSS Signal Splitter

Frequency Coverage: Full GNSS Spectrum

Overview

The Tallysman TW164 is a professional-grade full GNSS band signal splitter that connects one antenna up to four receivers, and supports GPS/QZSS-L1/L2/L5, QZSS-L6, GLONASS-G1/G2/G3, BeiDou-B1/B2/B2a/B3, Galileo-E1/E5a/E5b/E6, and L-band correction services.

GNSS has become a critical component in safety, security, timing, and infrastructure applications, all of which require very high availability. As a result, resilient fault-tolerant components are essential to avoid service interruptions.

The design of first-generation GNSS signal splitters suffered from a single point of failure: only one attached receiver powered the splitter and the antenna. If this receiver failed or was unplugged, all attached receivers also failed.

Tallysman's current-generation TW164 Smart Power GNSS signal splitter provides two additional key features:

First, it accepts power from all attached GNSS receivers and selects power from a receiver using the following protocol. Port #1 is given priority if its voltage is within the specified range (3.0 V - 12.5 V). However, if port #1's receiver is disconnected or if its receiver power goes below the under-voltage or above the over-voltage specification, the TW164 will switch to the next port in numerical order, as long as its power and voltage are within the expected range. The switching and port selection is, therefore, deterministic.

Second, if the antenna fails and does not draw current, the TW164 will provide the receiver powering the antenna with a current draw lower than 1 mA, indicating an antenna fault.

The TW164 offers the best in-class performance in terms of noise figure, isolation, and linearity. In addition, it is packaged in a robust, compact, lightweight, and water-proof (IP67) corrosion-protected aluminum housing.



Applications

- GNSS signal distribution
- High-availability applications
- Network and infrastructure timing
- GNSS receiver testing

Features

- Accepts power from all attached receivers
- Automatically switches on power failure of one receiver
- Antenna failure detection/indication
- Rugged military-grade aluminum enclosure
- Amplification to compensate for signal-splitting loss
- Very low noise figure
- IP67-compliant

Benefits

- Allows use of up to four GNSS receivers with one antenna
- Fits in line with antenna cable
- Robust package
- Suitable for harsh environments

About Tallysman: With global headquarters and manufacturing in Ottawa, Canada, Tallysman is a leading manufacturer of high-precision antennas and components for Global Navigation Satellite System (GNSS) applications. Tallysman's mission is to support the needs of a new generation of positioning systems by delivering unprecedented antenna precision at competitive prices. Learn more at www.tallysman.com

Revision: 1.0

Contact us:
info@tallysman.com
T: +1 613 591-3131

TW164 1-to-4 Port Smart Power GNSS Signal Splitter

Frequency Coverage: Full GNSS Spectrum

Electrical Specifications

Parameter	Conditions / Description	Minimum	Typical	Maximum	Units
Frequency Range	Bandwidth supported	1100	-	1700	MHz
Gain	-	-1.0	0.0	1.0	dB
Impedance	-	-	50.0	-	Ω
Noise Figure	All Receiver Ports	-	3.5	3.8	dB
Output Isolation	-	45.0	-	-	dB
Input/Output SWR	-	-	1.4:1 1.1:1	1.5:1 1.2:1	ratio
Input Gain Compression Point (P1dB)	Gain = 0 dB	-21.0	-17.0	-14.0	dBm
3rd Order Intercept (IIP3)	Gain = 0 dB	-11.0	-7.0	-4.0	dBm
RF Input (Damage Threshold)	Maximum RF Input without damage	-	-	5.0	dBm
Amplitude Balance	Between Ports	-	0.1	0.5	dB
Phase Balance	Between Ports	-	2.0	4.0	degrees ($^{\circ}$)
DC In	DC input on any port	3.0	-	12.5	VDC
Receiver Over-voltage	-	12.7	14.9	16.9	VDC
Receiver Under-voltage	-	2.3	2.5	2.8	VDC
Splitter Current	Current consumed by splitter	-	15.0	25.0	mA
Antenna Through Current	Maximum current provided to the antenna	-	-	230.0	mA

Mechanicals

Size	117.0 mm (l.) x 111.6 mm (w.) x 38.0 mm (h.)
Weight	405 g (type-N connectors) or 280 g (TNC connectors)
Connectors	5 TNC (female) or 5 type-N (female)
Enclosure	military-grade corrosion-protected aluminum (6061-T6)

Environmental

Operating Temperature	-40 °C to +85 °C
Storage Temperature	-50 °C to +95 °C
Vibration	-
Shock	-
Salt Fog	-
IEC 60529 - IP Rating	IEC-60529- IP67 (enclosure)
Compliance	RoHS, REACH and WEEE, EN60950-1, RED / CE Certified MIL-STD-810, FCC Part 15B and R&TTE equivalent.

Warranty

Parts and Labour	3-year standard warranty
------------------	--------------------------

Mechanical Diagram

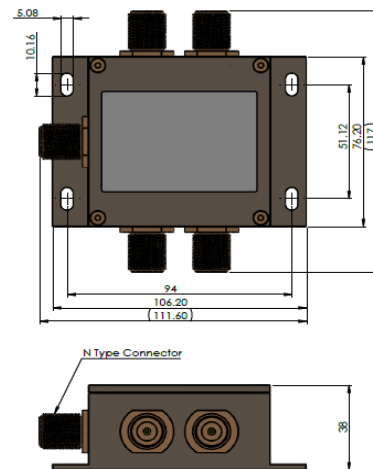

Ordering Information

Part Number **32-0164-xx-yy**

where xx = connectors: 14 = type-N (female) | 01 = TNC (female)
yy = gain: 00 = no gain | 10 = 10 dB gain

Please refer to our **Ordering Guide** to review available radomes and connectors at:
<https://www.tallysman.com/resource/tallysman-ordering-guide/>