

NOTES:

1. ELECTRICAL CHARACTERISTICS
 - 1-1. CONTACT RESISTANCE: 60 Milliohms Max
 - 1-2. INSULATION RESISTANCE: 1,000 Megohms Min.
 - 1-3. DIELECTRIC WITHSTANDING VOLTAGE: 250V AC FOR 1 MINUTE.
2. MECHANICAL CHARACTERISTICS
 - 2-1. OPERATION TEMPERATURE RANGE: -25°C~+70°C
 - 2-2. DURABILITY: 3000 CYCLES
3. MATERIAL:
 - 3-1. HOUSING: THERMOPLASTIC,UL 94-V0
 - 3-2. TERMINAL: PHOSPHOR BRONZE
 - 3-3. SHELL: STAINLESS STEEL
4. FINISHED:
 - 4-1. TERMINAL: Ni PLATED UNDER,Au PLATED ON CONTACT AREA F PLATED O SOLDER TAIL

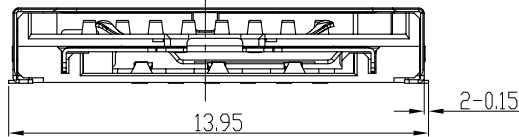

T-CARD P/N	PIN NAME
T1	DAT2
T2	CD/DAT3
T3	CMD
T4	VDD
T5	CLK
T6	VSS
T7	DAT0
T8	DAT1

NANO SIM P/N	PIN NAME
P1 A/B	VCC
P2 A/B	RST
P3 A/B	CLK
P5 A/B	GND
P6 A/B	VPP
P7 A/B	I/O



NINGBO KLS ELECTRONIC CO.,LTD

TOLERANCE: X.X ±0.30 X.XX ±0.25 X.XXX ±0.15 X.* ±2* X.X* ±0.5*	DRAWN BY : 陈一鸣	DATE : 2014-02-23	PART NAME: L-KLS1-SIM-34-3IN120-250	
	CHECKED BY: 马跃	DATE : 2014-02-23	PART NO.	MOLD NO.
 UNIT: mm [inch] SCALE: 1:1 SIZE: A4	APPROVED BY: 邱国夷	DATE : 2014-02-23	DRAW NO:	SHEET NO. 1 OF 1

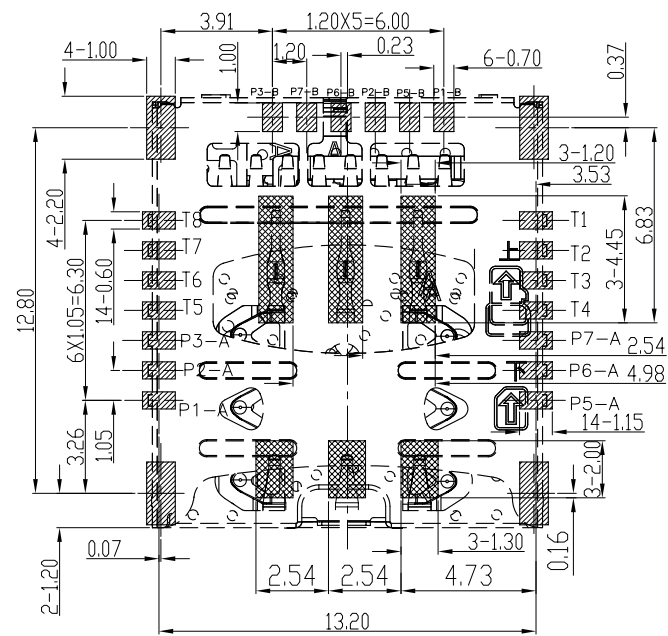
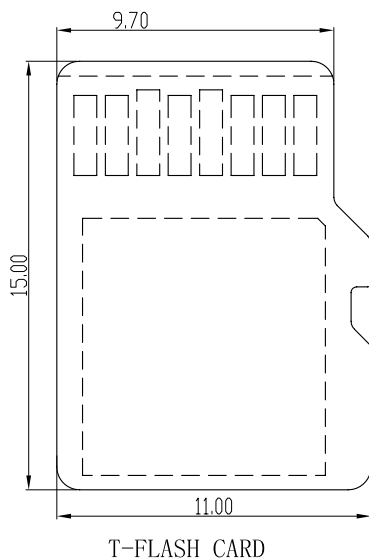
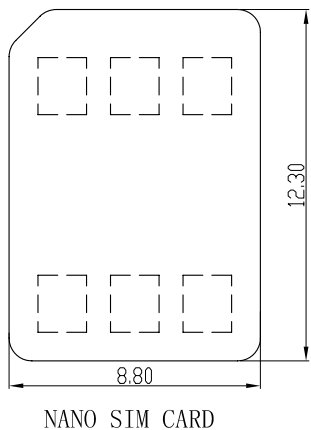
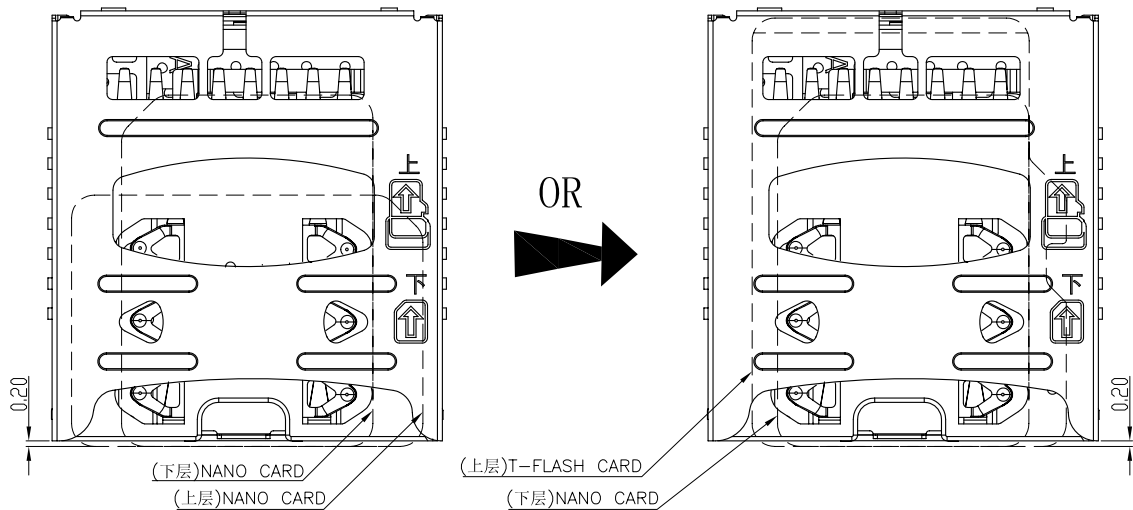

RECOMMENDED PCB LAYOUT(TOLERANCE ± 0.05)

RECOMMENDED METAL MASK T=0.12mm SCALE: 1:1

▨ PAD AREA ▩ NO CIKUIT AREA (TOP VIEW)



深圳市华宇创精密电子有限公司

TOLERANCE: X.X ± 0.30 X.XX ± 0.25 X.XXX ± 0.15 X.* $\pm 2^*$ X.* $\pm 0.5^*$	DRAWN BY : 陈一鸣	DATE : 2014-02-23	PART NAME: 2.5H 3选2双层卡座
	CHECKED BY: 马跃	DATE : 2014-02-23	PART NO.: HYC34-3IN120-250
 UNIT: mm [inch] SCALE: 1:1 SIZE: A4	APPROVED BY: 邱国夷	DATE : 2014-02-23	PART NO.: HYC34-3IN120-250
			DRAW NO.: HYC-SIM16120801
			SHEET NO.: 1 OF 1

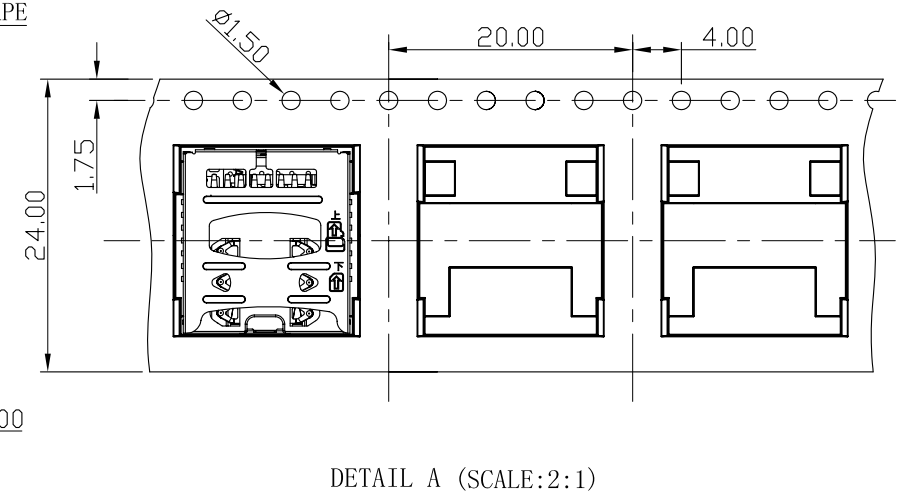
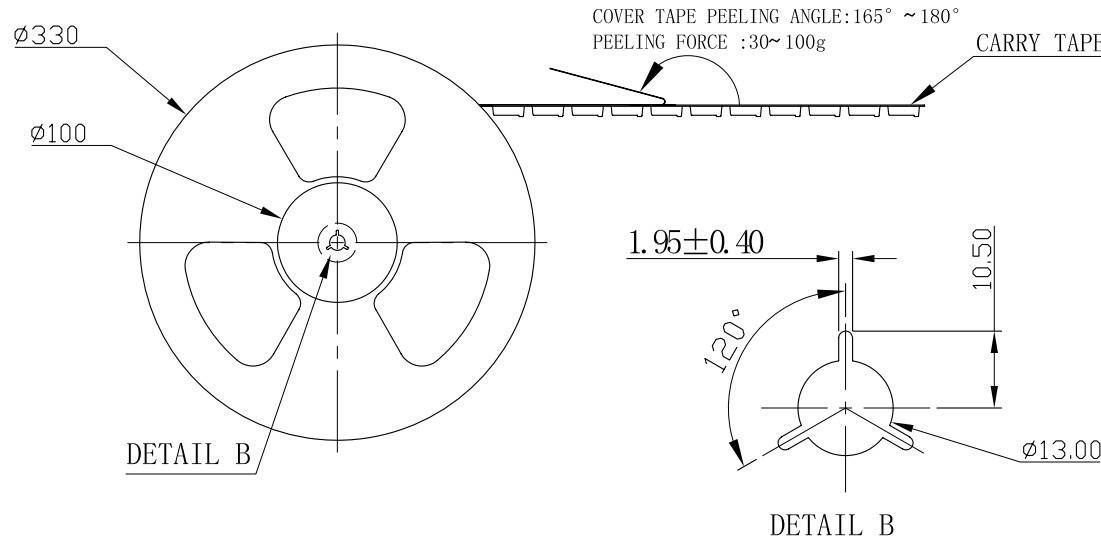
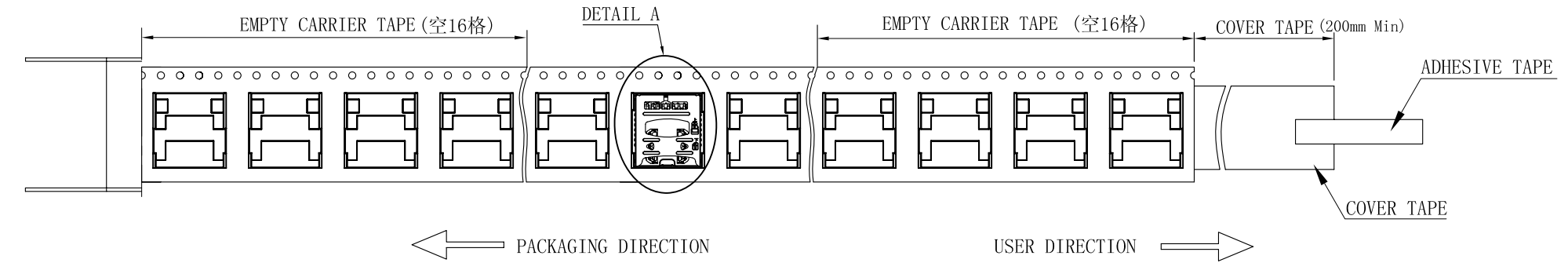

1	HYC30-3IN220-250	1000	12	12000	340X340X352
ITEM	PRODUCT NO.	QTY/REEL	REEL/CARTON	QTY/CARTON	CARTON SIZE

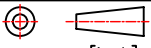
 深圳市华宇创精密电子有限公司			
TOLERANCE: X.X ±0.30 X.XX ±0.25 X.XXX ±0.15 X.* ±2* X.X* ±0.5*	DRAWN BY : 陈一鸣	DATE : 2014-02-23	PART NAME: 包装图
	CHECKED BY: 马跃	DATE : 2014-02-23	PART NO.
 UNIT: mm [inch] SCALE:1:1 SIZE: A4	APPROVED BY: 邱国夷	DATE : 2014-02-23	MOLD NO.
			DRAW NO:
		SHEET NO. 1 OF 1	