

Rev.	BCN No.	APPR
A	BCN-1106161	IVAN WANG 06/16' 11

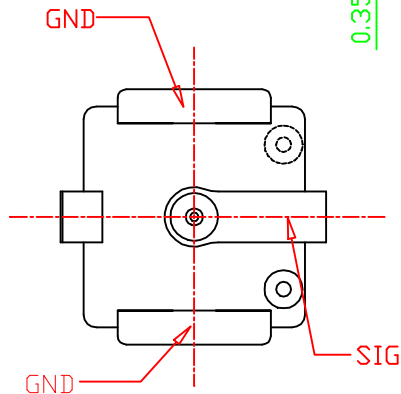
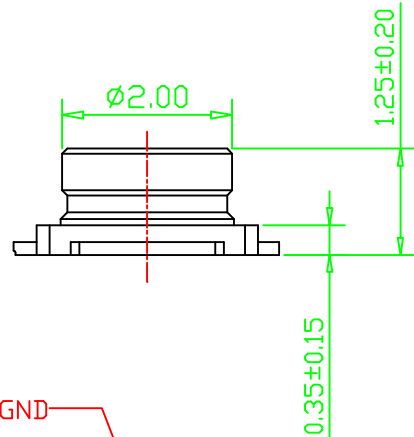
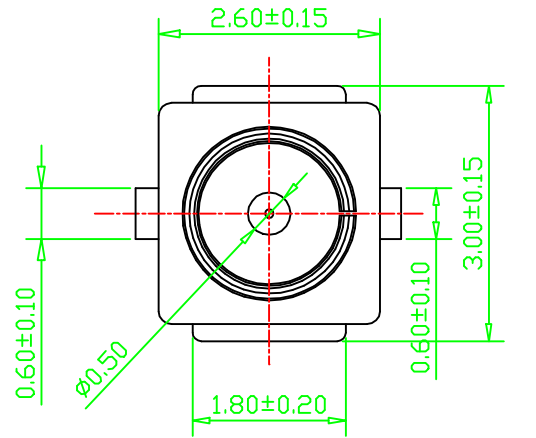

NOTES:

1. ELECTRICAL CHARACTERISTICS:

- 1.1 CURRENT RATING: 0.5A Max;
- 1.2 IMPEDANCE: 500HM NOMINAL.

2. MECHANICAL CHARACTERISTICS:

- 2.1 OPERATING TEMP. -40° TO 90° ;
- 2.2 VSWR UP TO 3 GHz: 1.3MAX;
3GHz TO 6GHz: 1.3MAX;
- 2.3 DURABILITY: 30CYCLES.

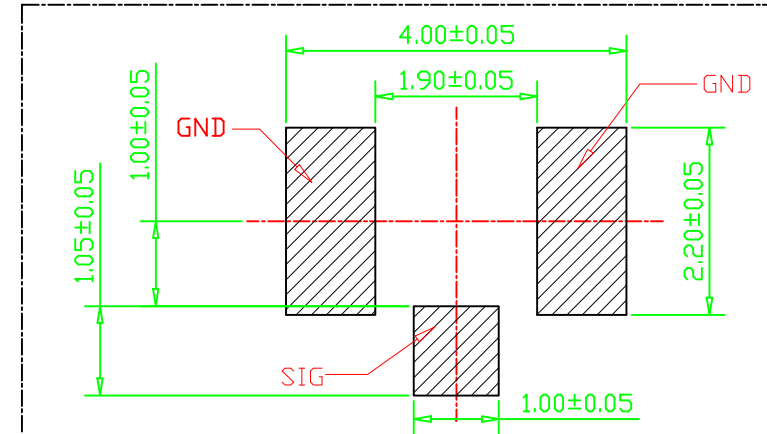

RECOMMENDED PC BOARD PATTERN DRAWING

3	CONTACT	磷青铜	Ni UNDER PLATE, Au PLATED AT CONTACT AREA	1	包圆端子镀金 不加倒角 FOR RF1N0016-C05-RF
			Ni UNDER PLATE, Ag PLATED AT CONTACT AREA	1	包圆端子镀银 不加倒角FOR RF1N0016-C04-RF
2	CONTACT	黄铜	Ni UNDER PLATE, Au PLATED AT CONTACT AREA	1	抽引端子 FOR RF1N0016-C04/C05/C06-RF
1	HOUSING	LCP UL94V-0	N/A	1	包圆端子镀金、包圆端子镀银 不加倒角FOR RF1N0016-C04/C05-RF
				1	包圆端子镀金 加倒角FOR RF1N0016-C06-RF
项次	名称	说明	电镀规格	数量	备注

UNITS	X.±	X'.±	PART NO. 20441	图号: YG-IPEX-20441-001
	.xx± 0.10	.xx° ±		
mm	.xxx±	.xxx° ±	Series: RF ANTENNA BOARD END	视角
				比例
DRAWN	ELI DUAN 06/16' 11			第 1 张
CHECKED	ELI DUAN 06/16' 11			共 1 张
APPROVAL	IVAN WANG 06/16' 11			