

SSL990XF



SSL990XF Extended-Filter Housed Full-Band GNSS Low-Profile Antenna

Frequency: GPS/QZSS-L1/L2/L5, QZSS-L6, GLONASS-G1/G2/G3, Galileo-E1/E5a/E5b/E6, BeiDou-B1/B2/B2a/B3, NavIC-L5
Coverage: + L-Band correction services

Overview

The patent-pending SSL990XF low-profile cross dipole antenna with parasitic resonators is designed for precision positioning, covering the GPS/QZSS-L1/L2/L5, QZSS-L6, GLONASS-G1/G2/G3, Galileo-E1/E5a/E5b/E6, BeiDou-B1/B2/B2a/B3, and NavIC-L5 frequency bands, including the satellite-based augmentation system (SBAS) available in the region of operation [WAAS (North America), EGNOS (Europe), MSAS (Japan), or GAGAN (India)], as well as L-band correction services.

The SSL990XF utilizes Tallysman's latest wideband antenna element design. The antenna element provides 67 MHz of signal bandwidth supporting the entire upper GNSS band and L-Band corrections (1539 - 1606 MHz) and 136 MHz of the lower band signal bandwidth (1164 - 1300 MHz). The other key component of the antenna is the axial ratio, which is a measure of how well the antenna captures the broadcast Right Hand Circular Polarized (RHCP) signal and mitigates the reflected LHCP signals. The Tallysman SSL990XF has a high peak gain of 2.5 dBi and ≤ 1.5 dB (typical) axial ratio at zenith, enabling excellent multipath mitigation and a very precise phase centre.

The SSL990XF features Tallysmans eXtended Filter (XF) and industry-leading low current, low-noise amplifier (LNA) that includes an integrated low-loss pre-filter to prevent harmonic interference from high-amplitude signals, such as 700 MHz band LTE and other near-band cellular signals. As the radio frequency spectrum has become more congested, the signals or harmonic frequencies of new LTE bands [e.g. 800MHz x 2 = 1600MHz (GLONASSG1)] can affect GNSS antennas and receivers. In North America, planned Ligado signals at 1525 - 1536 MHz can especially impact GNSS antennas that support space-based L-band correction services (1539 - 1559 MHz). New LTE signals in Europe [Band 32 (1452 - 1496 MHz)] and Japan [Bands 11 and 21 (1476 - 1511 MHz)] have also been observed to interfere with GNSS signals. In addition, Inmarsat satellite communication (uplink: 1626.5 - 1660.5 MHz) can also affect GNSS signals. The new Tallysman XF antennas have been designed to mitigate out-of-band signals and prevent GNSS antenna saturation. Tallysman's custom XF filtering mitigates all existing signals and new Ligado and LTE signals, enabling the antennas and attached GNSS receivers to perform optimally.

Weighing only 50g, the light and compact SSL990XF features a precision-tuned cross dipole element that provides excellent axial ratios and operates without the requirement of a ground plane. The SSL990XF is housed in a weatherproof (IP67) enclosure and is mounted using either adhesive tape or a mounting collar that includes a water proofing O-ring. Two antenna cable connector options are available the first is a female SMA and the second is an MCX. It is an ideal antenna for precision UAV and all applications where light weight and precision matters.



Applications

- Autonomous unmanned aerial vehicles (UAVs)
- Precision GNSS positioning
- Precision land survey positioning
- Mission-critical GNSS timing
- Marine and avionics systems

Features

- Very low noise preamp (2.5 dB typ.)
- Axial ratio (≤ 1.5 dB at zenith)
- High LNA gain (28 dB typ. | 35 dB typ.)
- Low current (25 mA typ. | 31 mA typ.)
- ESD circuit protection (15 kV)
- Invariant performance from 2.2 to 16 VDC
- REACH and RoHS compliant

Benefits

- Extremely light (50 g)
- Excellent RH circular polarized signal reception
- Great multipath rejection
- Increased system accuracy
- Excellent signal-to-noise ratio
- Industrial temperature range

About Tallysman: With global headquarters and manufacturing in Ottawa, Canada, Tallysman is a leading manufacturer of high-precision antennas and components for Global Navigation Satellite System (GNSS) applications. Tallysman's mission is to support the needs of a new generation of positioning systems by delivering unprecedented antenna precision at competitive prices. Learn more at www.tallysman.com

Contact us:
info@tallysman.com
T: +1 613 591-3131

SSL990XF Extended-Filter Housed Full-Band GNSS Low-Profile Antenna

Frequency Coverage: GPS/QZSS-L1/L2/L5, QZSS-L6, GLONASS-G1/G2/G3, Galileo-E1/E5a/E5b/E6, BeiDou-B1/B2/B2a/B3, NavIC-L5
+ L-Band correction services

Antenna (Measured with 100 mm ground plane)

Technology Full-spectrum, RHCP cross dipole antenna

		Gain	Axial Ratio
		dBic typ. at Zenith	dB at Zenith
GNSS			
GPS / QZSS	L1	2.5	≤ 1.5
	L2	2.1	≤ 1.0
	L5	1.0	≤ 1.0
GLONASS	G1	2.0	≤ 1.5
	G2	2.5	≤ 1.0
	G3	2.0	≤ 1.0
Galileo	E1	2.5	≤ 1.5
	E5A	1.0	≤ 1.0
	E5B	2.0	≤ 1.0
	E6	2.0	≤ 1.0
BeiDou	B1	2.5	≤ 1.5
	B2a	2.0	≤ 1.0
	B2b	1.0	≤ 1.0
	B3	2.0	≤ 1.0
IRNSS / NavIC	L5	1.0	≤ 1.5
QZSS	L6	2.0	≤ 1.0
L-Band Services (1525 MHz - 1559 MHz)		2.5	≤ 1.5
Satellite Communications			
Iridium		-	-
Globalstar		-	-
Phase Centre			
PC Variation	< 5 mm typ.		
Phase Centre Offset	TBD		

Mechanicals

Mechanical Size	60.0 mm (dia.) x 25.0 mm (h.)
Weight	50 g
Radome	EXL-9330
Mount	Adhesive Tape or Trapping Ring
Available Connectors	SMA Female or MCX

Environmental

Operating Temperature	-45 °C to +85 °C
Storage Temperature	-55 °C to +95 °C
Vibration	TBD
Shock	TBD
Salt Fog	TBD
IP Rating	TBD
Compliance	IPC-A-610, FCC, RED / CE Mark, RoHS, REACH

Warranty:

Parts and Labour	3-year standard warranty
------------------	--------------------------

Low Noise Amplifier (LNA) - Measured at 3V and 25°C

Frequency Bandwidth		Out of Band Rejection
Lower Band	1559 - 1606 MHz	≥ 85 dB @ ≤ 0950 MHz ≥ 70 dB @ ≤ 1125 MHz ≥ 75 dB @ ≥ 1350 MHz
L-Band - Correction Services	1539 - 1559 MHz	≥ 65 dB @ ≤ 1500 MHz ≥ 45 dB @ ≤ 1525 MHz ≥ 05 dB @ ≤ 1536 MHz ≥ 30 dB @ ≥ 1626 MHz ≥ 65 dB @ ≥ 1650 MHz
Upper Band	1164 - 1300 MHz	≥ 65 dB @ ≥ 1650 MHz

Architecture	Pre-filter → LNA
Gain	28 dB typ. 35 dB typ.
Noise Figure	2.5 dB typ.
VSWR	< 1.5:1 typ. 1.8:1 max.
Supply Voltage Range	2.2 to 16 VDC
Supply Current	25 mA typ. (28 dB) 31 mA typ. (35 dB)
ESD Circuit Protection	15 kV air discharge
P 1dB Output	13.3 dBm @ L1 13.1 dBm @ L2/L5
Group Delay	20 ns @ L1 3 ns @ L2 31 ns @ L5 48 ns @ L5

Mechanical Diagram

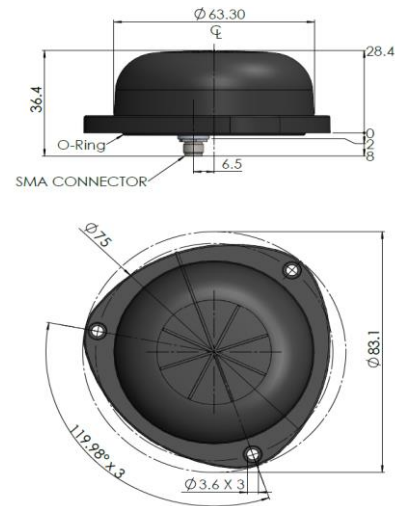

Ordering Information

Part Number **33-SSL990XF-GG-xx**

where, GG = gain (28 or 35 dB);
xx = connector type (SMA Female = 20, MCX = 19)