

FEATURES

1. Better price and higher performance
2. Support small customization on typical parameter
3. Flexible and low cost as discrete component
4. Continuous short-circuit protection
5. No-load input current as low as 5mA
6. Operating ambient temperature range: -50°C to +105°C
7. Full load start up at -50°C
8. High efficiency up to 86.5%
9. Support Hot Plug
10. Load regulation rate lower to 7%
11. Compact SMD package
12. I/O isolation test voltage 1.5k VDC
13. Industry standard pin-out



3 years
Warranty

Selection Guide

Part No.	Input Voltage(VDC)	Output		Full Load Efficiency(%) Min./Typ.	Capacitive Load(μF) Max.
	Nominal (Range)	Voltage (VDC)	Current(mA) Max./Min.		
B0503XT-1WR3K	5 (4.5-5.5)	3.3	303/30	70/74	2400
B0505XT-1WR3K		5	200/20	84.5/86.5	2400
B0509XT-1WR3K		9	111/12	79/83	1000
B0512XT-1WR3K		12	84/9	79/83	560
B0515XT-1WR3K		15	67/7	79/83	560
B0524XT-1WR3K		24	42/4	81/85	220

Input Specifications

Item	Operating Conditions		Min.	Typ.	Max.	Unit
Input Current (full load / no-load)	5VDC input	3.3VDC/5VDC output	-	270/5	286/10	mA
		9VDC/12VDC output	-	241/12	254/20	
		15VDC/24VDC output	-	241/18	254/30	
Reflected Ripple Current*			-	15	-	
Surge Voltage (1sec. max.)	5VDC input		-0.7	-	9	VDC
Input Filter			Capacitance filter			
Hot Plug			Support			

Note: * Refer to DC-DC Converter Application Notes for detailed description of reflected ripple current test method.

Output Specifications

Item	Operating Conditions		Min.	Typ.	Max.	Unit
Voltage Accuracy			See output regulation curve (Fig. 1)			
Linear Regulation	Input voltage change: ±1%	3.3VDC output	-	-	1.5	-
		Other outputs	-	-	1.2	
Load Regulation	10%-100% load	3.3VDC output	-	15	20	%
		5VDC output	-	10	15	
		9VDC output	-	8	10	
		12VDC output	-	7	10	
		15VDC output	-	6	10	
		24VDC output	-	5	10	

Ripple & Noise*	20MHz bandwidth	Other outputs	–	30	75	mVp-p
		24VDC output	–	50	100	
Temperature Coefficient	Full load		–	±0.02	--	%/°C
Short-circuit Protection			Continuous, self-recovery			

Note: * The "parallel cable" method is used for Ripple and Noise test, please refer to DC-DC Converter Application Notes for specific information.

General Specifications

Item	Operating Conditions	Min.	Typ.	Max.	Unit	
Isolation	Input-output Electric Strength Test for 1 minute with a leakage current of 1mA max.	1500	–	–	VDC	
Insulation Resistance	Input-output resistance at 500VDC	1000	–	–	MΩ	
Isolation Capacitance	Input-output capacitance at 100kHz/0.1V	–	20	–	pF	
Operating Temperature	Derating when operating temperature ≥ 85°C, (see Fig. 2)	-50	–	105	°C	
Storage Temperature		-55	–	125		
Case Temperature Rise	Ta=25°C					
			3.3VDC output	–	25	
			Others	–	15	
Storage Humidity	Non-condensing	–	–	95	%RH	
Reflow Soldering Temperature		Peak temp. ≤ 245°C, maximum duration time ≤ 60s over 217°C.				
Switching Frequency	Full load, nominal input voltage	–	270	–	kHz	
MTBF	MIL-HDBK-217F@25°C	3500	–	–	k hours	
Moisture Sensitivity Level (MSL)	IPC/JEDEC J-STD-020D.1	Level 1				

Note: * For actual application, please refer to IPC/JEDEC J-STD-020D.1.

Mechanical Specifications

Case Material	Black plastic; flame-retardant and heat-resistant (UL94V-0)
Dimensions	13.20 x 11.40 x 7.25 mm
Weight	1.4g(Typ.)
Cooling methods	Free air convection

EMC Specifications

Emissions	CE	CISPR32/EN55032	CLASS B (see Fig. 4 for recommended circuit)
	RE	CISPR32/EN55032	CLASS B (see Fig. 4 for recommended circuit)
Immunity	ESD	IEC/EN61000-4-2	Air ±8kV, Contact ±4kV perf. Criteria B

Typical Characteristic Curves

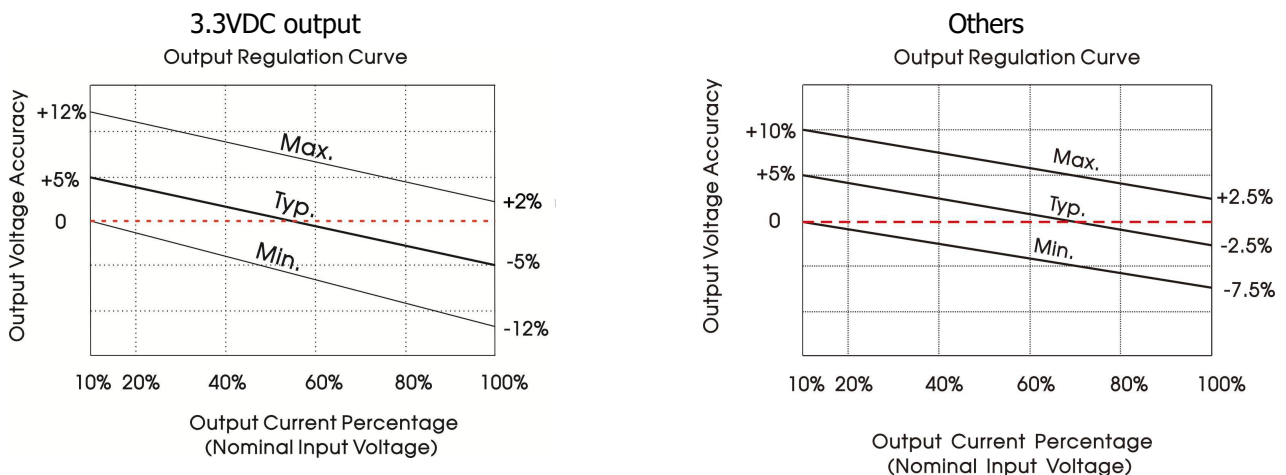

Fig. 1

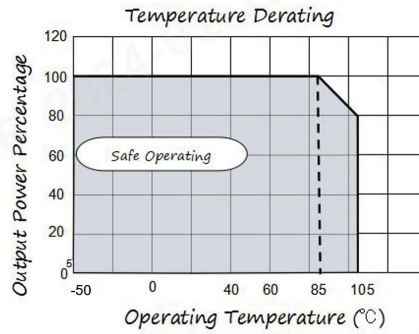
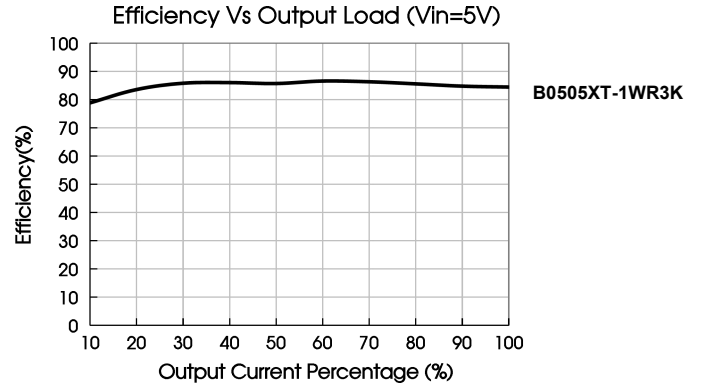
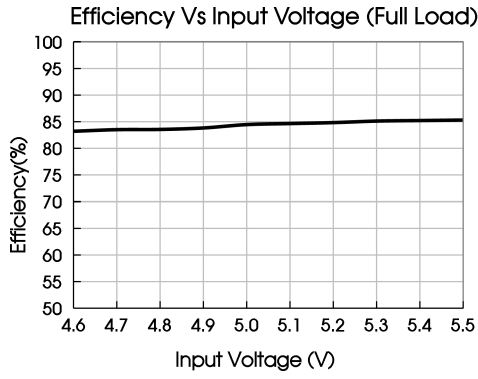

Fig. 2

Design Reference

1. Typical application circuit

Input and/or output ripple can be further reduced, by connecting a filter capacitor from the input and/or output terminals to ground as shown in Fig. 3.

Choosing suitable filter capacitor values is very important for a smooth operation of the modules, particularly to avoid start-up problems caused by capacitor values that are too high. For recommended input and output capacitor values refer to Table 1.

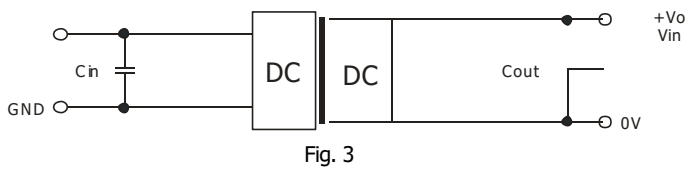

Fig. 3

Recommended capacitive load value table (Table 1)

Vin	Cin	Vo	Cout
5VDC	4.7µF/16V	3.3/5VDC	10µF/16V
		9VDC	4.7µF/16V
		12VDC	2.2µF/25V
		15VDC	1µF/25V
		24VDC	0.47µF/50V

2. EMC (CLASS B) compliance circuit

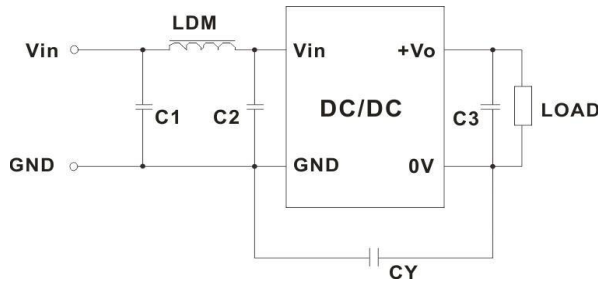

Fig. 4

EMC recommended circuit value table (Table 2)

Input voltage 5VDC	Output voltage	3.3/5/9VDC	12/15/24VDC
	Emissions	C1/C2	4.7 μ F /25V
	CY	--	1nF /2KVDC HEC C1206X102K202T JOHANSON 202R18W102KV4E
	C3	Refer to the Cout in table 1	
	LDM	6.8 μ H	6.8 μ H

Note: In the case of actual use, the requirements for EMI are high, it is subject to CY.

Dimensions and Recommended Layout

THIRD ANGLE PROJECTION 

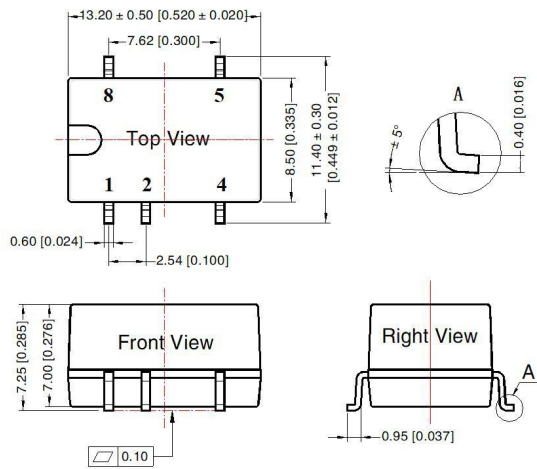

Note:
Unit: mm[inch]
Pin section tolerances: ± 0.10 [± 0.004]
General tolerances: ± 0.25 [± 0.010]

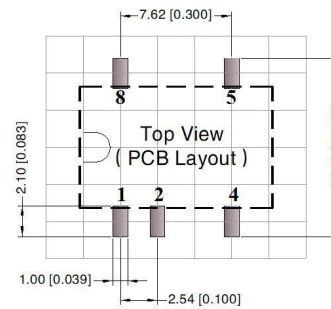

Note: Grid 2.54*2.54mm

Pin-Out	
Pin	Mark
1	GND
2	Vin
4	0V
5	+Vo
8	NC

NC: Pin to be isolated from circuitry

Notes & Instructions

1. If the product works under the minimum required load, it cannot guarantee that the performance of the product complies with all the performance indicators in this manual;
2. The maximum capacitive load is tested under the input voltage range and full load condition;
3. Unless otherwise stated, all indexes in this manual are measured at Ta=25°C, humidity <75%RH, nominal input voltage and rated output load;
4. All index testing methods in this manual are based on the enterprise standards of the company;
5. Our company can provide product customization, specific needs can directly contact our technical staff;