

FEATURES

1. Continuous short-circuit protection
2. No-load input current as low as 8mA
3. Operating ambient temperature range: -50°C to +105°C
4. High efficiency up to 85%
5. I/O isolation test voltage: 4k VDC (5.2k/6k VDC Option)
6. Start up at -50°C with full load

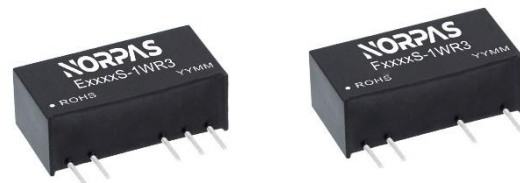

**3 years
Warranty**

Selection Guide

Part No.	Input Voltage (VDC)	Output		Full Load Efficiency (%) Min./Typ.	Capacitive Load(μF) Max.*
	Nominal (Range)	Voltage (VDC)	Current (mA) Max./Min.		
E0303S-1WR3	3.3 (2.97-3.63)	±3.3	±150/±15	74/78	1200
E0305S-1WR3		±5	±100/±10	78/82	1200
E0309S-1WR3		±9	±56/±6	81/85	470
E0312S-1WR3		±12	±42/±5	78/82	220
E0315S-1WR3		±15	±34/±4	78/82	220
E0324S-1WR3		±24	±21/±2	80/84	100
F0303S-1WR3		3.3	303/30	75/79	2400
F0305S-1WR3		5	200/20	78/82	2400
F0309S-1WR3		9	111/11	81/85	1000
F0312S-1WR3		12	83/8	78/82	560
F0315S-1WR3		15	67/7	78/82	560
F0324S-1WR3		24	42/4	80/84	220
E0503S-1WR3		5 (4.5-5.5)	±3.3	±152/±15	70/74
E0505S-1WR3	±5		±100/±10	78/82	1200
E0509S-1WR3	±9		±56/±6	79/83	470
E0512S-1WR3	±12		±42/±5	79/83	220
E0515S-1WR3	±15		±34/±4	79/83	220
E0524S-1WR3	±24		±21/±3	81/85	100
F0503S-1WR3	3.3		303/30	70/74	2400
F0505S-1WR3	5		200/20	81/82	2400
F0509S-1WR3	9		111/12	79/83	1000
F0512S-1WR3	12		84/9	79/83	560
F0515S-1WR3	15		67/7	79/83	560
F0524S-1WR3	24		42/4	81/85	220
F0909S-1WR3	9 (8.1-9.9)		9	111/12	77/81

E1203S-1WR3	12 (10.8-13.2)	±3.3	±152/±15	71/75	1200
E1205S-1WR3		±5	±100/±10	76/80	1200
E1209S-1WR3		±9	±56/±5	76/80	470
E1212S-1WR3		±12	±42/±5	77/81	220
E1215S-1WR3		±15	±34/±4	77/81	220
E1224S-1WR3		±24	±21/±2	76/80	100
F1203S-1WR3		3.3	303/30	71/75	2400
F1205S-1WR3		5	200/20	76/80	2400
F1209S-1WR3		9	111/12	76/80	1000
F1212S-1WR3		12	83/9	76/80	560
F1215S-1WR3		15	67/7	77/81	560
F1224S-1WR3		24	42/5	77/81	220
E1505S-1WR3	15 (13.5-16.5)	±5	±100/±10	76/80	1200
E1509S-1WR3		±9	±56/±5	76/80	470
E1512S-1WR3		±12	±42/±5	76/80	220
E1515S-1WR3		±15	±34/±4	77/81	220
E1524S-1WR3		±24	±21/±2	77/81	100
F1505S-1WR3		5	200/20	76/80	2400
F1509S-1WR3		9	111/12	76/80	1000
F1512S-1WR3		12	83/9	76/80	560
F1515S-1WR3		15	67/7	77/81	560
F1524S-1WR3		24	42/5	77/81	220
E2403S-1WR3	24 (21.6-26.4)	±3.3	±150/±15	72/76	1200
E2405S-1WR3		±5	±100/±10	74/80	1200
E2409S-1WR3		±9	±56/±5	74/80	470
E2412S-1WR3		±12	±42/±5	75/81	220
E2415S-1WR3		±15	±34/±4	73/79	220
E2424S-1WR3		±24	±21/±2	74/80	100
F2403S-1WR3		3.3	303/30	69/75	2400
F2405S-1WR3		5	200/20	73/79	2400
F2407S-1WR3		7.2	139/13	74/80	1000
F2409S-1WR3		9	111/12	74/80	1000
F2412S-1WR3		12	83/9	75/81	560
F2415S-1WR3		15	67/7	75/81	560
F2424S-1WR3		24	42/5	75/81	220

Note: *The specified maximum capacitive load for positive and negative output is identical.

*with H5 suffix means 5200 V isolation , Example: F0505S-1WR3H5

*with H6 suffix means 6000V isolation, Example: F0505S-1WR3H6

Input Specifications

Item	Operating Conditions		Min.	Typ.	Max.	Unit
Input Current (full load / no-load)	3.3VDC input	3.3VDC output	-	384/10	405/-	mA
		other output	-	370/18	389/-	
	5VDC input	3.3VDC/5VDC output	-	270/8	286/-	
		9VDC/12VDC output	-	241/12	254/-	
		15VDC/24VDC output	-	241/18	254/-	
	9V input		-	137/8	144/-	
	12V input	3.3VDC output	-	112/8	118/-	
		5VDC/9VDC output	-	105/8	110/-	
		12VDC/15VDC output	-	103/8	109/-	

Input Current (full load / no-load)	12V input	24VDC output	–	105/8	110/–	mA
	15V input	5VDC/9VDC/12VDC output	–	84/8	88/–	
		15VDC/24VDC output	–	83/8	87/–	
	24V input	3.3VDC output	–	55/8	58/–	
		5VDC/9VDC/24VDC output	–	53/8	57/–	
		12VDC output	–	53/8	56/–	
		15VDC output	–	53/8	58/–	
Reflected Ripple Current*			–	15	–	
Surge Voltage(1sec. max.)	3.3VDC input		-0.7	–	5	VDC
	5VDC input		-0.7	–	9	
	9VDC input		-0.7	–	12	
	12VDC input		-0.7	–	18	
	15VDC input		-0.7	–	21	
	24VDC input		-0.7	–	30	
Input Filter				Capacitance filter		
Hot Plug				Unavailable		
Note: * Refer to DC-DC Converter Application Notes for detailed description of reflected ripple current test method.						

Output Specifications

Item	Operating Conditions		Min.	Typ.	Max.	Unit
Voltage Accuracy			See output regulation curves (Fig. 1)			
Linear Regulation	Input voltage change: ±1%	3.3VDC output	–	–	1.5	–
		Other output	–	–	1.2	
Load Regulation	3.3VDC input 10% -100% load	3.3VDC output	–	12	18	%
		Other output	–	8	15	
	5VDC input 10% -100% load	3.3VDC output	–	15	20	
		5VDC output	–	10	15	
		9VDC output	–	8	10	
		12VDC output	–	7	10	
		15VDC output	–	6	10	
	9/12/15/24VDC input 10%-100% load	24VDC output	–	5	10	
		3.3VDC output	–	15	20	
		5VDC output	–	10	15	
Ripple & Noise*	20MHz bandwidth	24VDC output	–	50	100	mVp-p
		Other output	–	30	75	
Temperature Coefficient	Full load		–	±0.02	–	%/°C
Short-Circuit Protection			Continuous, self-recovery			
Note: * The "parallel cable" method is used for Ripple and Noise test, please refer to DC-DC Converter Application Notes for specific information.						

General Specifications

Item	Operating Conditions		Min.	Typ.	Max.	Unit
Isolation	Input-output electric strength test for 1 minute with a leakage current of 1mA max.	F_S-1WR3/E_S-1WR3	4000	--	–	VDC
		F_S-1WR3H5/E_S-1WR3H5	5200	--	–	
		F_S-1WR3H6/E_S-1WR3H6	6000	--	–	
Insulation Resistance	Input-output resistance at 500VDC		1000	--	–	MΩ
Isolation Capacitance	Input-output capacitance at 100kHz/0.1V		–	20	–	pF
Operating Temperature	5VDC input	Derating when operating temperature ≥ 85°C, (see Fig. 2)	-50	--	105	°C
Operating Temperature	Other input	Derating when operating temperature ≥ 100°C, (see Fig. 2)	-50	--	105	°C
Storage Temperature			-55	--	125	
Case Temperature Rise	Ta=25°C		–	25	–	
Pin Soldering Resistance Temperature	Soldering spot is 1.5mm away from case for 10 seconds		–	--	300	

Storage Humidity	Non-condensin g	3.3/5VDC input	–	--	95	%RH
		Other input	5	--	95	
Vibration	9/12/15/24VDC input		10-150Hz, 5G, 0.75mm. along X, Y and Z			
Switching Frequency	Full load, nominal input voltage	3.3VDC input	–	220	–	kHz
		5VDC input	–	270	–	
		9/12/15/24VDC input	–	260	–	
MTBF	MIL-HDBK-217F@25°C		3500	--	–	k hours

Mechanical Specifications

Case Material	Black plastic; flame-retardant and heat-resistant (UL94V-0)
Dimensions	19.65 x 6.00 x 10.16mm
Weight	2.1g(Typ.)
Cooling Method	Free air convection

EMC Specifications

Emissions	CE	CISPR32/EN55032 CLASS B
	RE	CISPR32/EN55032 CLASS B
Immunity	ESD	IEC/EN61000-4-2 Air ±8kV, Contact ±6kV perf. Criteria B

Note: Refer to Fig. 4 for recommended circuit test.

Typical Characteristic Curves

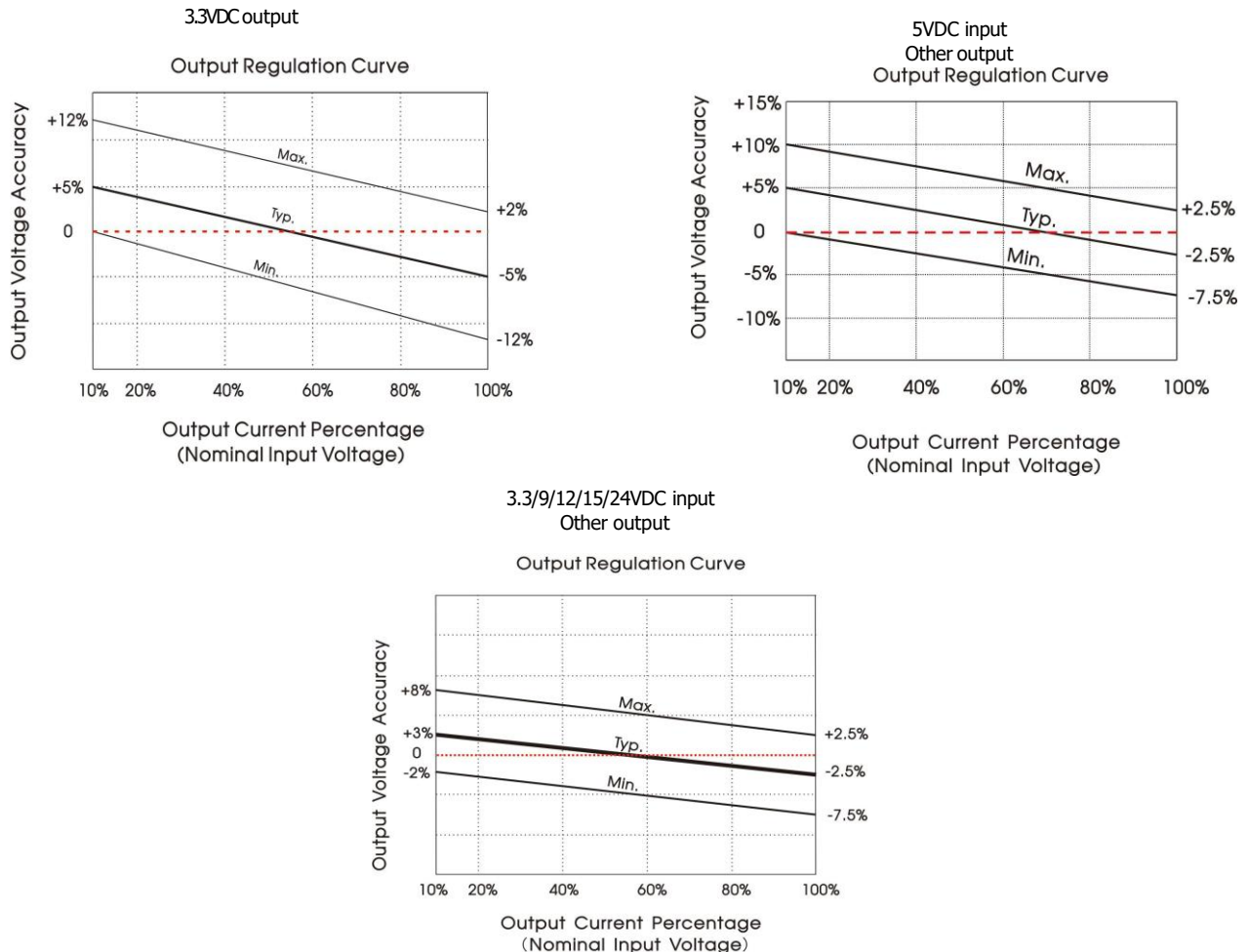

Fig. 1

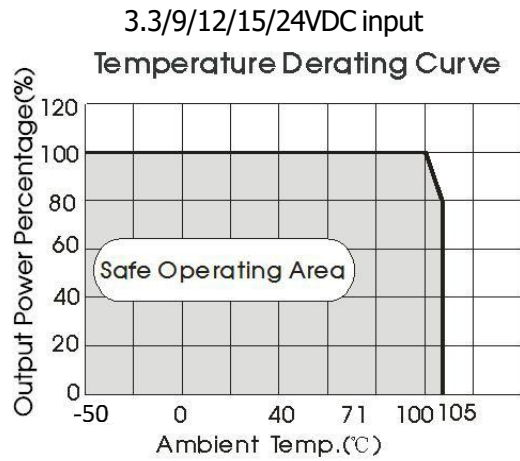
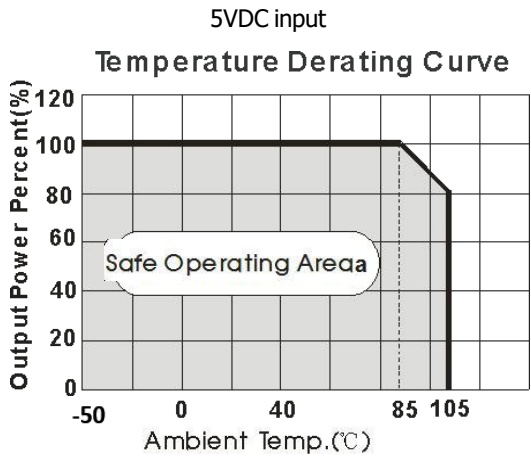
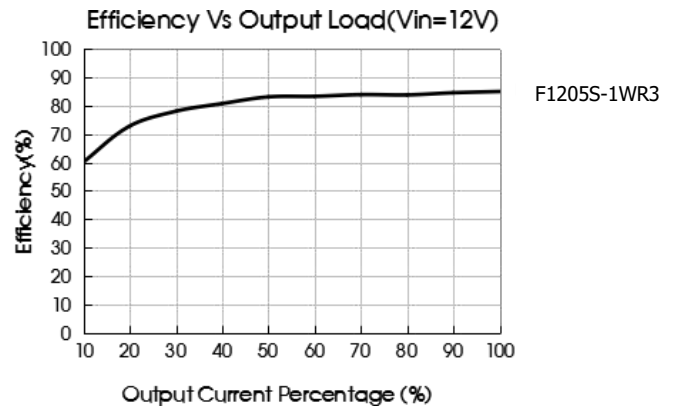
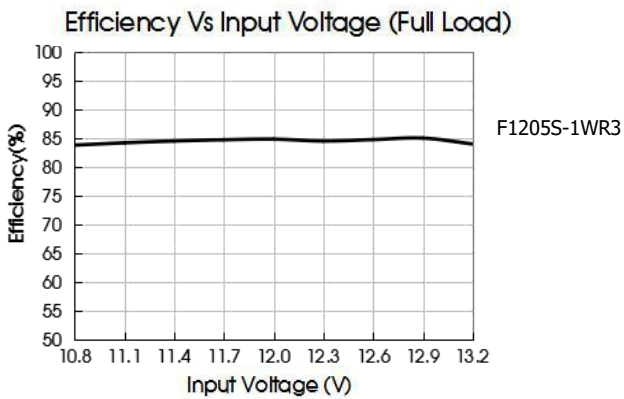
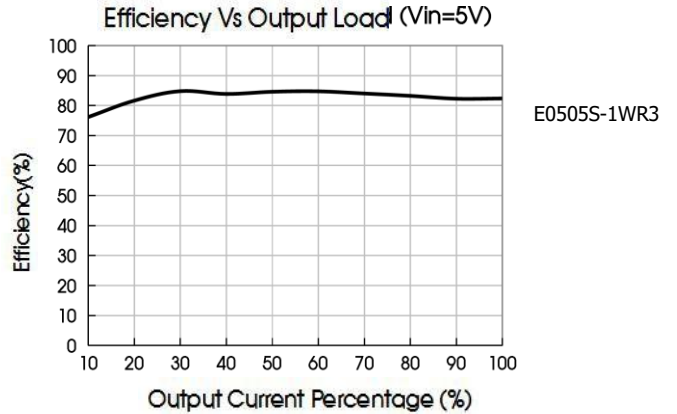
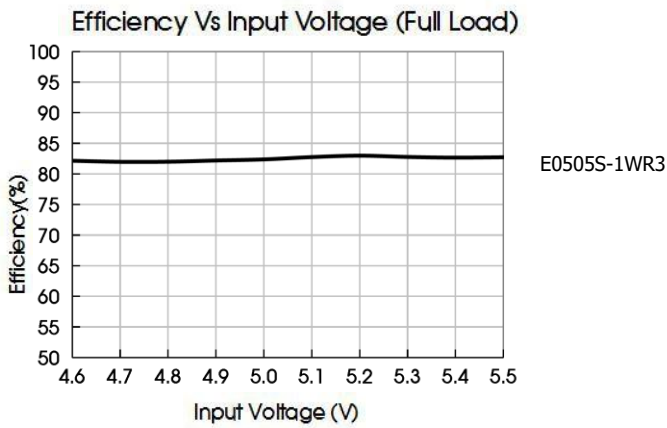
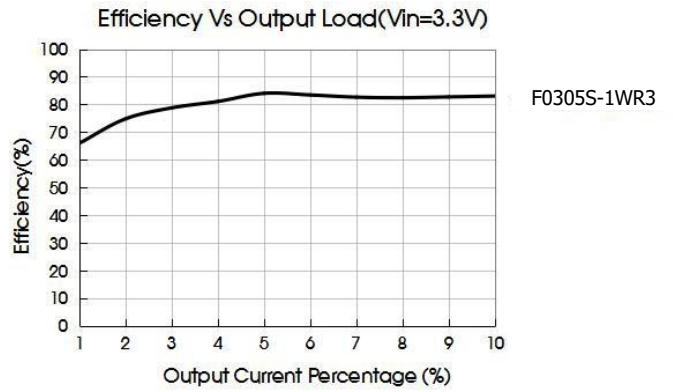
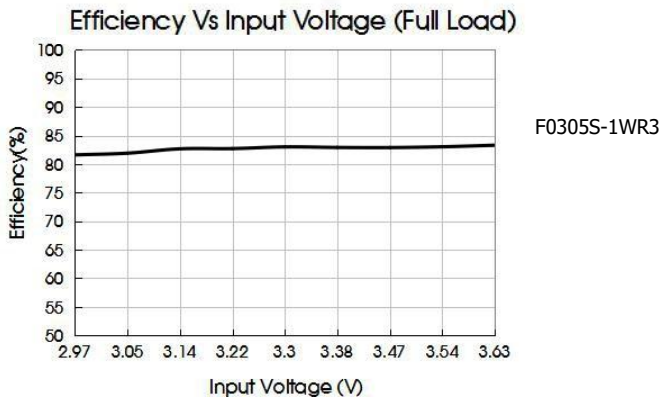

Fig. 2



Design Reference

1. Typical application

Input and/or output ripple can be further reduced, by connecting a filter capacitor from the input and/or output terminals to ground as shown in Fig. 3. Choosing suitable filter capacitor values is very important for a smooth operation of the modules, particularly to avoid start-up problems caused by capacitor values that are too high. For recommended input and output capacitor values refer to Table 1.

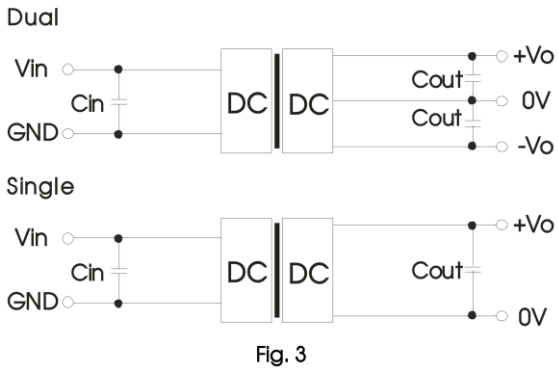

Fig. 3

Table 1: Recommended input and output capacitor values

Vin	Cin	Single output	Cout	Dual output	Cout
3.3VDC	10µF/16V	3.3VDC	10µF/16V	±3.3VDC	4.7µF/16V
5VDC	4.7µF/16V	5VDC	10µF/16V	±5VDC	4.7µF/16V
9VDC	2.2µF/25V	7.2VDC	2.2µF/16V	±9VDC	1µF/16V
12VDC	2.2µF/25V	9VDC	2.2µF/16V	±12VDC	1µF/25V
15VDC	2.2µF/25V	12VDC	2.2µF/25V	±15VDC	0.47µF/25V
24VDC	1µF/50V	15VDC	1µF/25V	±24VDC	0.47µF/50V
-	-	24VDC	1µF/50V	-	-

2. EMC compliance circuit

Dual

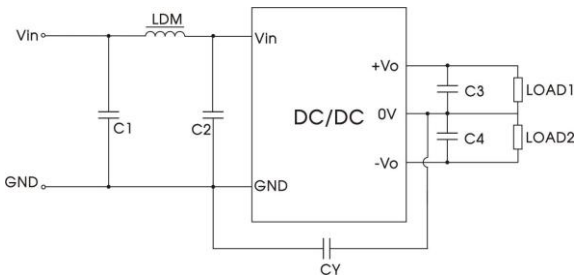

Single

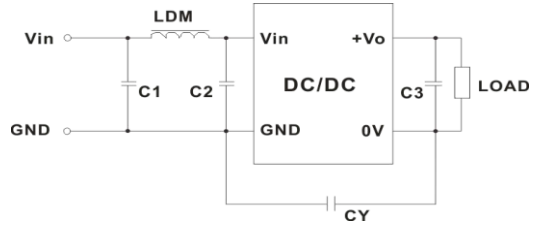
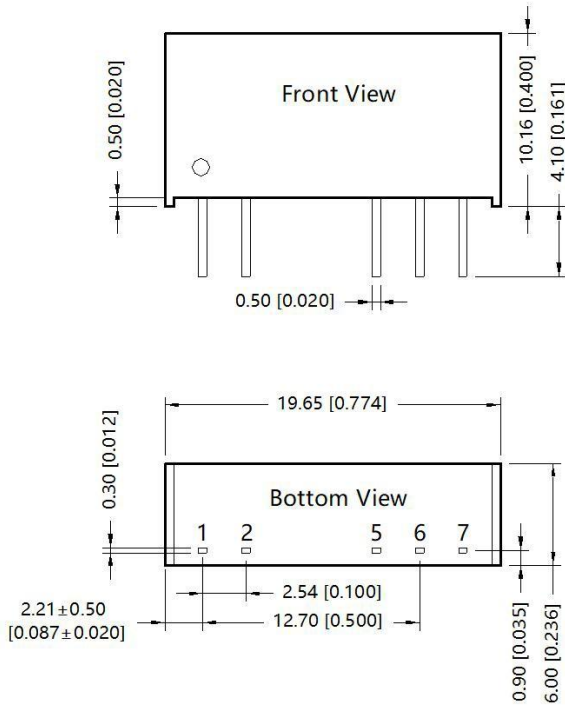

Fig. 4

Table 2: EMC recommended circuit value table

Input voltage		3.3VDC		5VDC		Other input
Output voltage		3.3/5VDC	9/12/15/24VDC	3.3/5/9VDC	12/15/24VDC	-
EMI	C1/C2	4.7uF/16V	4.7uF/16V	4.7uF/25V	4.7uF/25V	4.7uF/50V
	CY	-	270pF /4kVDC VISHAY HGZ102MBP TDK CD45-E2GA102M-GKA	100pF/4kV	1000pF/4kV	270pF /3kVDC
	C3/C4	Refer to the Cout in table 1				
	LDM	6.8µH				

Dimensions and Recommended Layout



Note:
 Unit: mm[inch]
 Pin section tolerances: ±0.10[±0.004]
 General tolerances: ±0.25[±0.010]

THIRD ANGLE PROJECTION

Duals Output

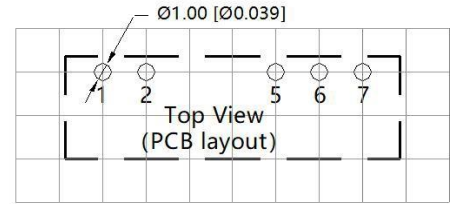

Singles Output

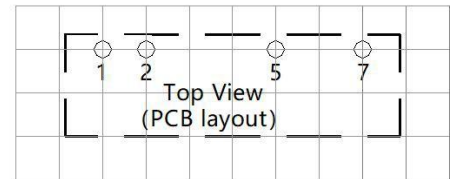

Note: Grid 2.54*2.54mm

Pin	Single	Dual
1	V _{in}	V _{in}
2	GND	GND
5	0V	-V _o
6	No Pin	0V
7	+V _o	+V _o

Notes & Instructions

1. If the product works under the minimum required load, it cannot guarantee that the performance of the product complies with all the performance indicators in this manual;
2. The maximum capacitive load is tested under the input voltage range and full load condition;
3. Unless otherwise stated, all indexes in this manual are measured at Ta=25°C, humidity <75%RH, nominal input voltage and rated output load;
4. All index testing methods in this manual are based on the enterprise standards of the company;
5. Our company can provide product customization, specific needs can directly contact our technical staff;

NORPAS-POWER TECHNOLOGY CO., LTD.

www.norpas-power.com Mail: info@norpas-power.com

Specifications can be changed without notice! Make sure you are using the latest documentation, downloadable at www.norpas-power.com

REV:07/2024